

IRB 4600 Industrial Robot

The IRB 4600 is a pioneer of the sharp robot generation; with enhanced features and new capabilities. The design has been optimized to make it superior for the targeted applications. The IRB 4600 enables more compact manufacturing cells with increased production output and higher quality - and that means improved productivity.

Sharpest accuracy

With the best accuracy in its class, the IRB 4600 can help you increase output with higher process speeds and lower scrap rates, resulting in improved productivity. This is particularly useful in materials handling, dispensing, machining, measuring, assembly and welding applications. In addition, the programming time is minimized since what you program is what you get, and that in the shortest possible cycle time. This is useful in all applications to shorten commissioning times and minimize production stops when new programs or work pieces are introduced.

Shortest cycle times

Thanks to the new compact and optimized design resulting in a low weight, the IRB 4600 can cut the cycle times of the industry benchmark by up to 25%. The maximum acceleration achievable is highest in its class, together with high maximum speeds. The high acceleration is possible to use to avoid obstacles or to follow the path. The benefit is increased production capacity and higher productivity.

Ultra-wide working range

You can position the IRB 4600 in the most favourable way with regard to reach, cycle time and auxiliary equipment. Flexible mounting with floor, tilted, semi-shelf or inverted mounting is very useful when you are simulating the best position for your application.



Compactness

The small footprint, the slim swing base radius around axis 1, the fine elbow behind axis 3, the small lower and upper arms, and the compact wrist all contribute to the most compact robot in its class. With the IRB 4600 you can create your production cell with reduced floorspace by placing the robot closer to the served machines, which also increases your output per m² and your productivity.

Best protection available

ABB has the most comprehensive protection program on the market and it will be even further enhanced with the IRB 4600. Foundry Plus includes IP 67, resistant paint, rust-protected mounting flange and protection for molten metal spits on non-moving cables on the rear of the robot and extra protection plates over the floor cable connections on the foot.

Optimize and go sharp

To get the IRB 4600 ready for the targeted applications you have access to high performing workpiece positioners, Track motions, and the motor unit range.

To simulate your production cell to find the optimal position for the robot and program it offline, RobotStudio is available on subscription together with PowerPacs for several applications.

If you would like to learn more about how to use the IRB 4600 in your applications and environments, you can watch simulations on several applications at www.abb.com/robotics

IRB 4600

Main applications

Machine tending, Material handling, Arc welding, Cutting, Dispensing, Assembly, Palletizing and packing, Measuring

Specification

Variants:	Reach	Payload	Armload
IRB 4600-60/2.05	2.05 m	60 kg	20 kg
IRB 4600-45/2.05	2.05 m	45 kg	20 kg
IRB 4600-40/2.55	2.55 m	40 kg	20 kg
IRB 4600-20/2.50	2.51 m	20 kg	11 kg
Number of axes:	6+3 external (up to 36 with MultiMove)		
Protection:	Standard IP67, as option Foundry Plus 2		
Mounting:	Floor, shelf, inverted or tilted		
IRC5 Controller variants:	Single cabinet, Dual cabinet		

Physical

Dimensions robot base:	512 x 676 mm
Robot height: IRB 4600-60/2.05 and IRB 4600-45/2.05	1727 mm
Robot height: IRB 4600-40/2.55 and IRB 4600-20/2.50	1922 mm
Robot weight:	412 to 435 kg

Performance

Position repeatability (RP)	0.05 - 0.06 mm
Path repeatability (RT)	0.13 - 0.46 mm (measured at speed 250 mm/s)

Movement

Axis movements:	Working range:	Maximum speed:
Axis 1	+180° to -180°	175°/s
Axis 2	+150° to -90°	175°/s
Axis 3	+75° to -180°	175°/s
Axis 4	+400° to -400°	250° (20/2.50 has 360°)/s
Axis 5*	+120° to -125°	250° (20/2.50 has 360°)/s
Axis 6	+400° to -400°	360° (20/2.50 has 500°)/s

* Axis 5 for IRB 4600-20/2.50 +120°-120°

Electrical connections

Supply voltage: 200-600 V, 50-60 Hz

Environment

Ambient temperature for mechanical unit:

During operation:	+5° C (41° F) to +45° C (113° F)
During transportation and storage:	-25° C (-13° F) to +55° C (131° F)
For short periods (max 24 h):	up to +70° C (158° F)
Relative humidity:	Max 95%
Safety:	Double circuits with supervisions, emergency stops and safety functions. 3-position enable device

Emission: EMC/EMI shielded

Data and dimensions may be changed without notice.

Working range

IRB 4600-60/2.05

IRB 4600-45/2.05

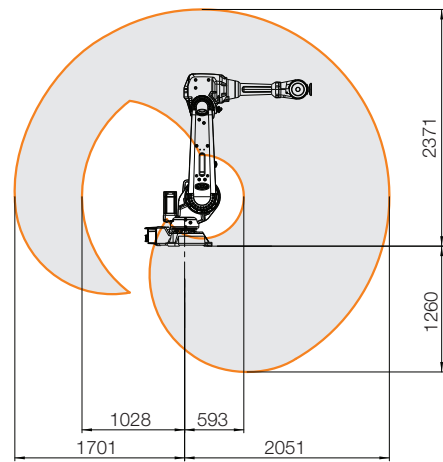

IRB 4600-60/2.05
IRB 4600-45/2.05

IRB 4600-40/2.55

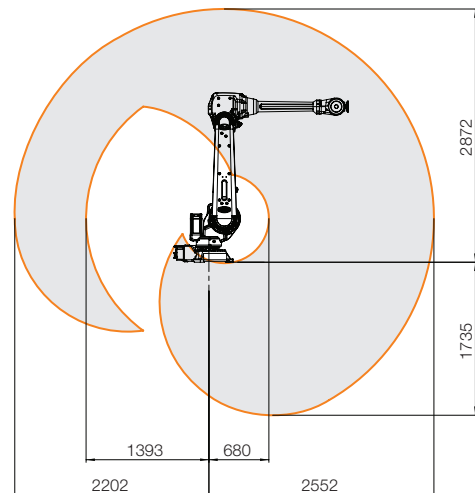

IRB 4600-20/2.50

