

AA-000

This drawing is property of
**HYUNDAI
 HEAVY INDUSTRIES CO.,LTD.**
 It is not to be copied or duplicated
 in any manner and shall not be submitted to
 outside parties without our written consent.

GENERAL
 TOLERANCE
 UNLESS NOTED

CASTING ±

LENGTH	Casting ±		
	FC	C ₁	C ₂
-120	1.0	1.5	
-250	1.5	2.0	
-400	2.0	3.0	
-800	3.0	4.0	
-1600	4.0	6.0	
-3150	-	10.0	
THICKNESS	Casting ±		
	FC	C ₁	C ₂
-10	1.0	1.5	
-18	1.5	2.0	
-30	2.0	3.0	
-50	2.0	3.5	

FCD C₁ C₂

LENGTH	FCD		
	FC	C ₁	C ₂
-120	1.5	2.0	
-250	2.0	2.5	
-400	2.5	3.5	
-800	4.0	5.0	
-1600	5.0	7.0	
-3150	-	10.0	
THICKNESS	FCD		
	FC	C ₁	C ₂
-10	1.2	2.0	
-18	1.5	2.5	
-30	2.0	3.0	
-50	2.5	4.0	

MACHINING ±

LENGTH	Machining ±		
	f	m	c
0.5-6	0.05	0.1	0.3
-30	0.10	0.2	0.5
-120	0.15	0.3	0.8
-315	0.2	0.5	1.2
-81	0.3	0.8	2.0
-24	0.5	1.2	3.0
-64	0.8	2.0	4.0
-84	-	3.0	5.0
-124	-	4.0	6.0
-164	-	5.0	7.0
-204	-	6.0	8.0

ROUGHNESS(S)

▽▽▽	0.8
▽▽	6.3
▽	12.5
▽	50
-	-

WELDING ±

LENGTH	Welding ±		
	W ₁	W ₂	W ₃
-120	1	2	3
-315	1	2	4
-81	2	3	6
-24	3	4	8
-64	4	6	11
-84	5	8	14
-124	6	7	18
-164	7	12	21
-204	8	14	24

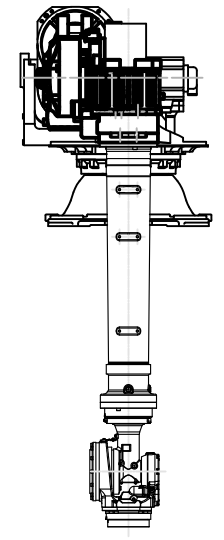
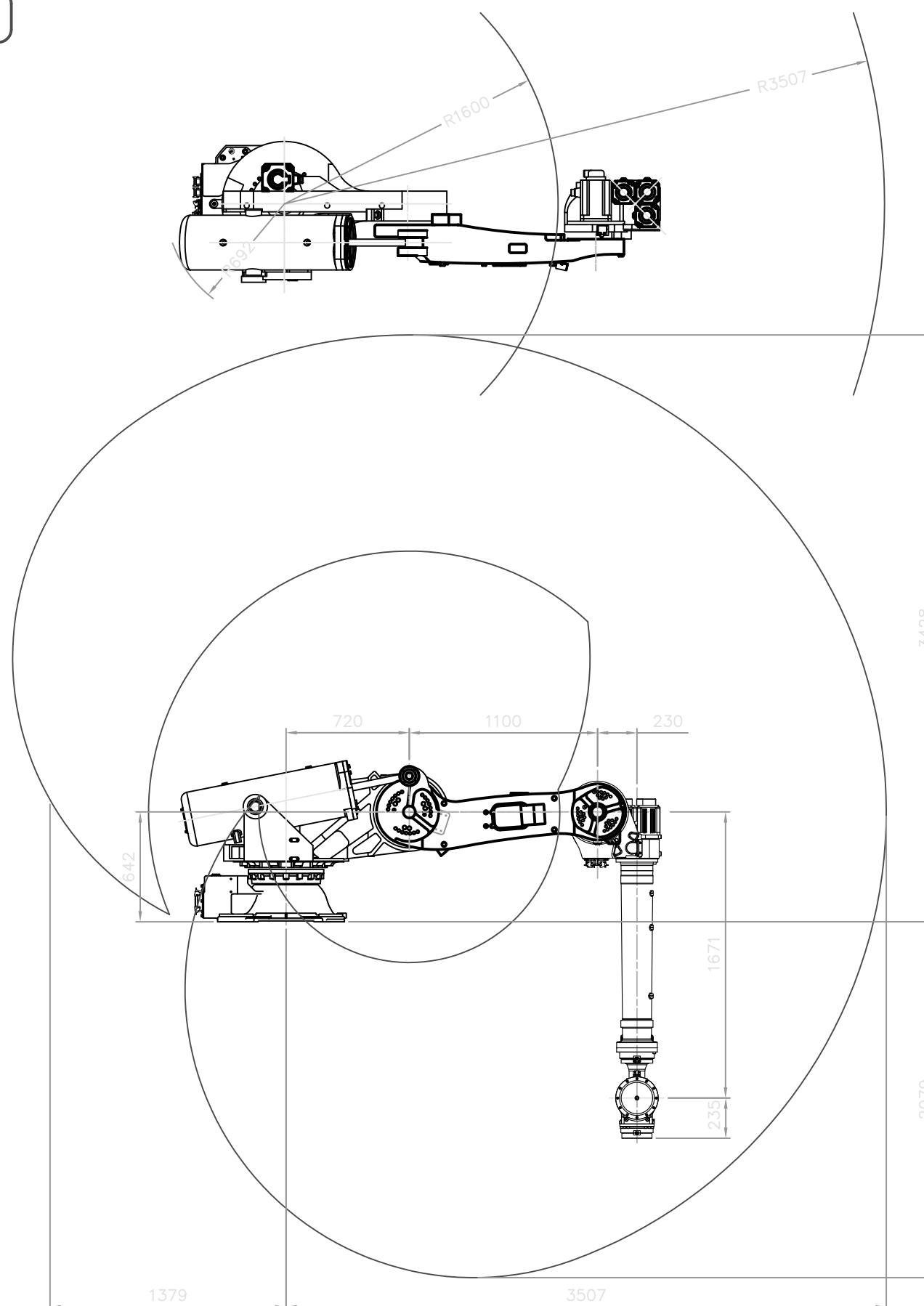

NO.	REASON FOR MODIFICATION	DATE	CHKD	APPD
▲				
▲				
▲				
▲				
▲	?? ??			

SCALE	1:15	MODEL	HH100SL-00	SET	
GROUP NO.		DESCRIPTION	TOTAL ASS'Y	DWG NO.	R11-550000-00
OLD DWG NO.				PART NO.	AA-000

HYUNDAI HEAVY INDUSTRIES
 CO.,LTD. ENGINE & MACHINERY